

COMMERCIAL FRAMING | SERIES 600
WIDE OFFSET 150mm FRAMING

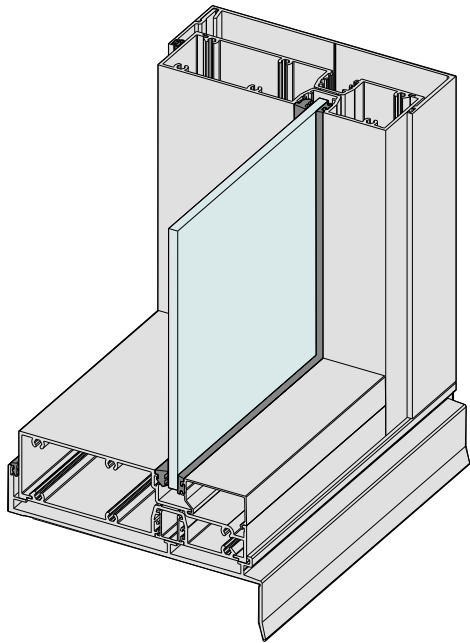

KEY FEATURES

- Series 600 wide shopfront framing is 150mm thick by 44mm wide with the glazing pocket offset. The product is ideal for frames spanning more than 3m high.
- The glazing pocket is set forward to allow use of 102mm or 80mm transoms from Series 400 and Series 80.
- We can fit a true captive glazing wedge on one side. This reduces the chance of vandalism.
- External wet top silicone glazing also available.
- There are several custom designed extrusions to cater for specific applications.
- Sub-sill included as we always recommend sub-sills under commercial framing.
- Sub-head to allow for building settlement.
- Two piece sub-jamb to simplify installation.
- Hinged door threshold.
- Awning sash inlay adaptors.
- Compatible with Series 50, 51 and 52 doors.

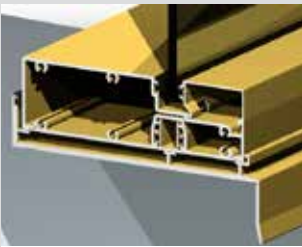

150mm offset glazing that maintains glazing line to Series 400 and 80 suites. Sub-sill has additional support leg under glass, to carry weight of heavy glass preventing frame dishing.

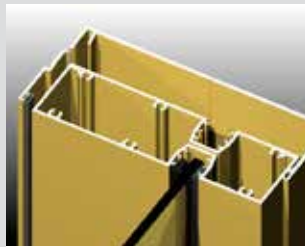

Sub-sill, sub-head and sub-jamb available.

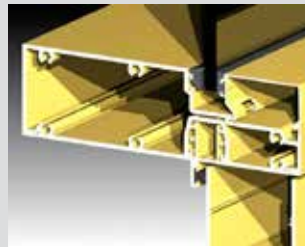

This detail shows the standard 150mm wide transom from Series 600. We can also fit the narrower transoms for Series 400 (102mm) or Series 80 (80mm).

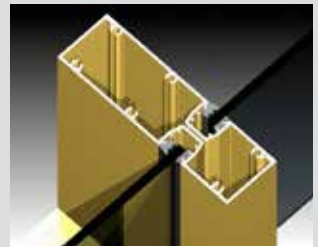

Various mullion details for site wind load conditions. We recommend expansion mullions on long runs of framing (over 6m).

GENERAL

Max Panel Height
Various

Max Panel Width
Various

Max Glass Thickness
10.38mm

Frame Depth
150mm

ENERGY

UW Range
4.6-6.4

SHGC Range
0.25-0.75

WEATHER

Maximum Water
600 Pa.

ACOUSTICS

This product has not been acoustics tested. AWS anticipates this product's acoustic performance will be in-line with Series 400.

